

# SDC Security Door Controls

801 Avenida Acaso, Camarillo, Ca. 93012 • (805) 494-0622 •  
www.sdcsecurity.com • E-mail: service@sdsecurity.com

## 30-4 Frame Preparation

Method of installation may vary per door, frame and lockset manufacturer.  
Left handed door installation shown.

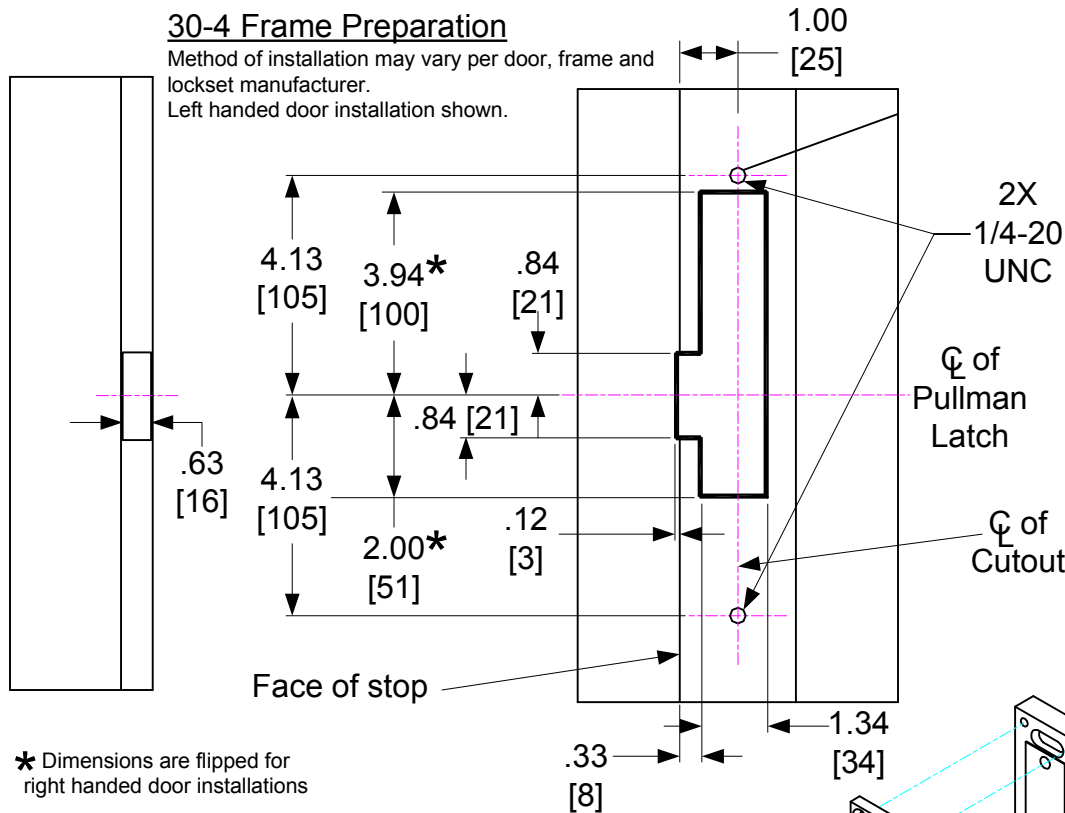

\* Dimensions are flipped for right handed door installations

## 30-4 ELECTRIC STRIKE AND FRAME, PREP. TEMPLATE

### NOTE:

Not compatible with SDC 6000 series Rim Devices.  
Check Manufacturers exit device template for compatibility.

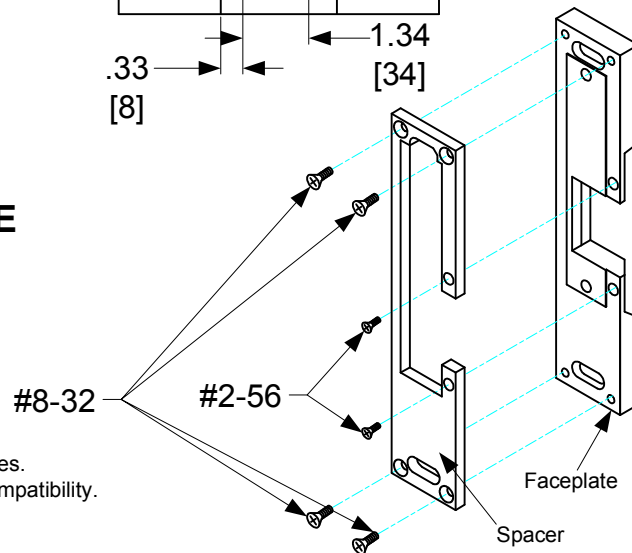

### Spacer Removal

A 1/4" spacer plate is preinstalled to the strike faceplate. Removal of the spacer plate will decrease the faceplate thickness from .75" to .50".

To remove spacer follow these steps:

1. Remove strike body from faceplate.
2. Remove four #8-32 screws and two #2-56 screws as shown on left.
3. Remove spacer.
4. Re-attach strike body to faceplate.

### Horizontal Adjustability

1. Loosen the two #1/4-20 socket cap screws as shown to the right.
2. Adjust strike to appropriate horizontal position.
3. Tighten the two #1/4-20 socket cap screws.
4. Lock down adjustment by installing the provided set screws.

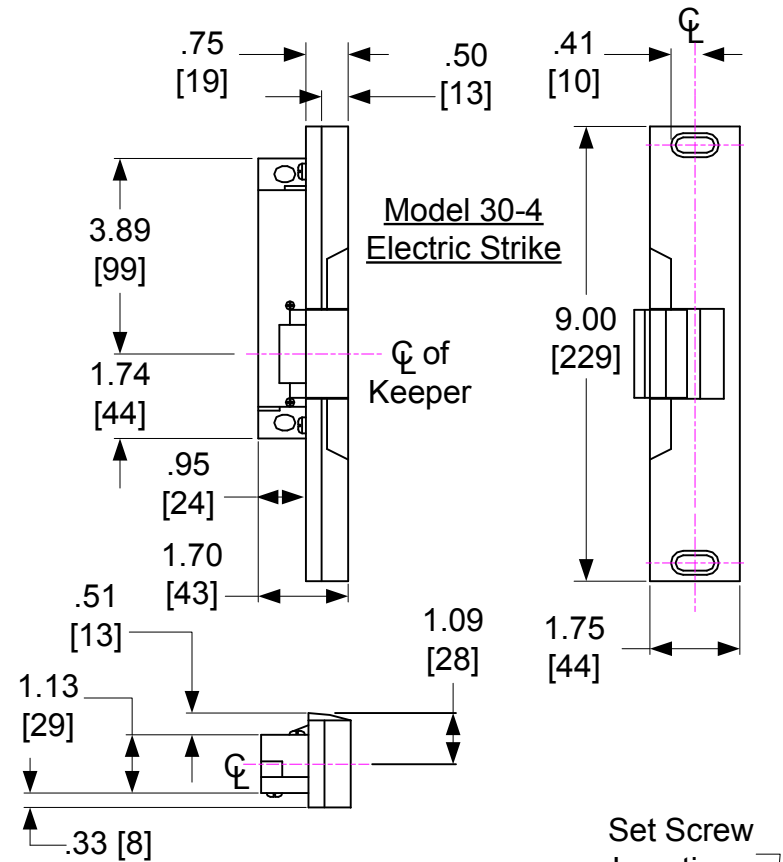

### Set Screw Locations

