

INSWINGING DOOR INSTALLATION WITH L- Z BRACKET

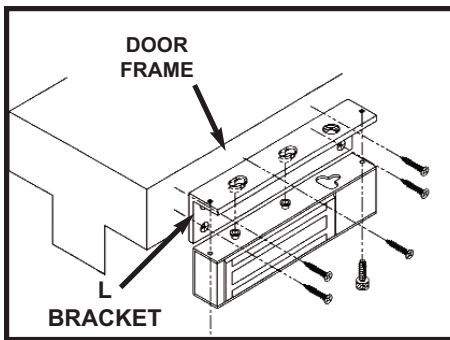

STEP 1

FASTEN THE L BRACKET ON THE DOOR FRAME IN A SUITABLE LOCATION.
MOUNT THE MAGNETIC LOCK TO THE L BRACKET.

MAKE SURE THAT THE MAGNETIC LOCK DOES NOT OBSTRUCT THE CLOSING OF THE DOOR.

CONNECT THE CORRECT VOLTAGE TO THE MAGNET.

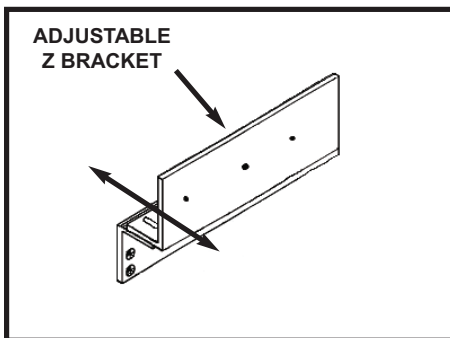

STEP 2

ASSEMBLE THE Z BRACKET WITH THE SOCKET HEAD CAP SCREWS PROVIDED. DO NOT TIGHTEN THE CAP SCREWS AT THIS TIME. THE Z BRACKET MUST BE ADJUSTABLE.

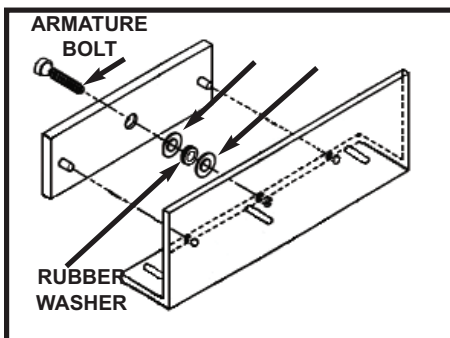

STEP 3

MOUNT THE ARMATURE PLATE TO THE ADJUSTABLE SECTION OF THE Z BRACKET WITH THE ARMATURE BOLT. DO NOT REMOVE THE RUBBER WASHER ATTACHED TO THE ARMATURE BOLT.

USE ONE RUBBER WASHER BETWEEN TWO METAL WASHERS ON THE ARMATURE BOLT. THE WASHER ASSEMBLY MUST BE BETWEEN THE ARMATURE PLATE AND THE ADJUSTABLE SECTION OF THE Z BRACKET.

APPLY THE SCREW LOCKING AGENT TO THE ARMATURE BOLT.

DO NOT OVER TIGHTEN. ARMATURE MUST ROCK TO ALIGN WITH THE MAGNET.

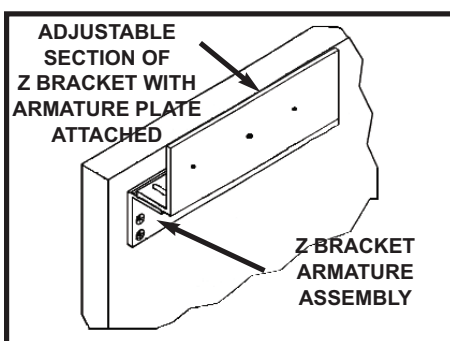

STEP 4

CLOSE THE DOOR AND ALIGN THE ARMATURE PLATE TO THE MAGNET AND APPLY POWER TO THE MAGNET. LET THE ARMATURE PLATE BOND TO THE MAGNET. BE SURE THE Z BRACKET ASSEMBLY IS FIRMLY AGAINST THE CLOSED DOOR.

TIGHTEN THE CAP SCREWS HOLDING THE Z BRACKET ARMATURE PLATE ASSEMBLY.

FASTEN THE Z BRACKET ASSEMBLY TO THE DOOR WITH THE SCREWS SUPPLIED.

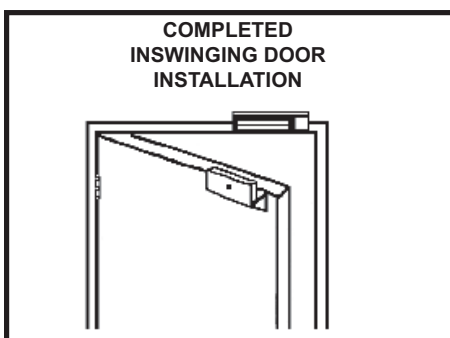

STEP 5

CHECK THE COMPLETED ALIGNMENT AND INSTALLATION OF THE MAGNET AND ARMATURE PLATE BY OPENING AND CLOSING THE DOOR BY ENERGIZING AND DE-ENERGIZING THE MAGNETIC LOCK SEVERAL TIMES.

THIS WILL INSURE THAT THE CORRECT OPERATION AND ALIGNMENT OF THE MAGNETIC LOCK HAS BEEN PROPERLY INSTALLED.