



# SECURITY DOOR CONTROLS

3580 Willow Lane, Westlake Village, CA 91361-4921 • (805) 494-0622 • Fax: (805) 494-8861  
 www.sdcsecurity.com • E-mail: service@sdsecurity.com

## INSTALLATION INSTRUCTIONS MODEL PBD2090A

### READ THOROUGHLY BEFORE INSTALLING

**CAUTION:** This device for center hung doors only

FAIL SECURE  
 (POWER UNLOCK)

#### INSTALLATION

1. Review the installations shown in figures A through D. Center line of panic device determines location of release.
2. The locking bolt will function as long as it enters the top latch bolt at some point. If it is not possible to line up on the panic device center line, a larger notch may have to be cut in the lock stile of the door to clear the lock latch bolt.
3. Remove bottom rod assembly.
4. A metal filler block must be placed in the top rail at the point of automatic relock switch. This block must be flush with the top of the door (required for the automatic relock switch). Because of variables, this filler block is not supplied by SDC. Notch inside top rail at relock switch.
5. After reinforcement tabs have been installed, attach power leads as shown in wire diagram.
6. Insert lock into mortise and attach with machine screws provided.

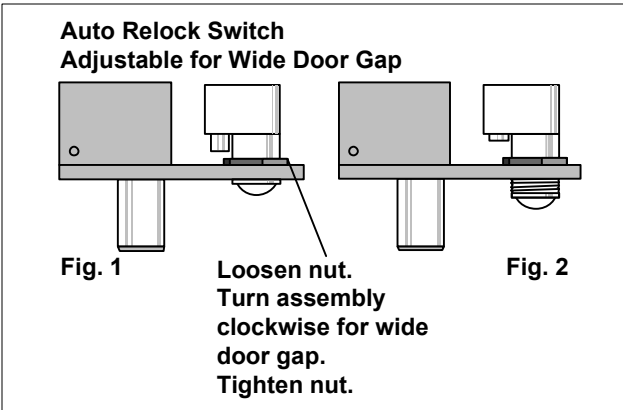
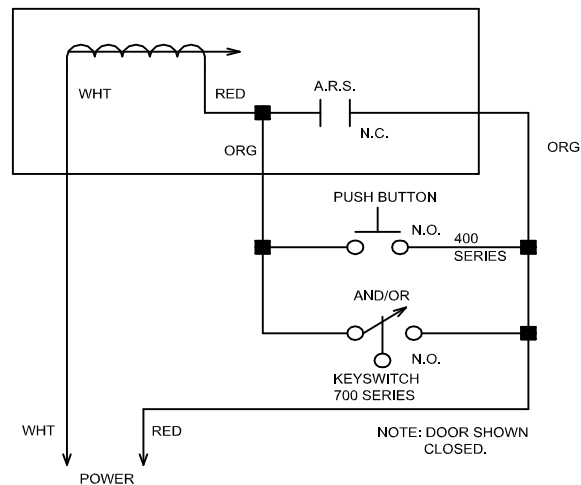

SPECIFICATIONS	TROUBLESHOOTING	
<p><b>Faceplate:</b> 10" x 1-1/2" x 1/8"</p> <p><b>I.D. Requirements:</b> 10" x 1-1/2" x 1-1/2"</p> <p><b>Solenoid:</b> Continuous Duty 2 Stage            24 VAC and 24 VDC available            Pull-in Coil – 57.6 watt/2.4 amp at 24VDC            Holding Coil – 8.4 watt/.35 amp at 24VDC</p> <p><b>Bolt:</b> Beveled stainless steel 1/2" diameter x 1/2" throw</p> <p><b>B</b> Bolt position indicates bolt locked or unlocked 5 amp at 30VDC</p> <p><b>D</b> Door position indicates door open or closed 5 amp at 30VDC</p>	<p><b>Problem</b></p> <p>Top latch will not stand up.</p> <p>Bolt will not retract.</p> <p>Bolt projects too soon.</p> <p>Bolt projects when door is open.</p>	<p><b>Solution</b></p> <p>Adjust top latch.</p> <p>Check voltage at lock. Check rating of transformer. Check for cracks in switch on side of lock body.</p> <p>Adjust auto relock switch</p> <p>ARS has been bypassed. Check wiring.</p>

# TYPICAL INSTALLATION FOR PANICLOCK

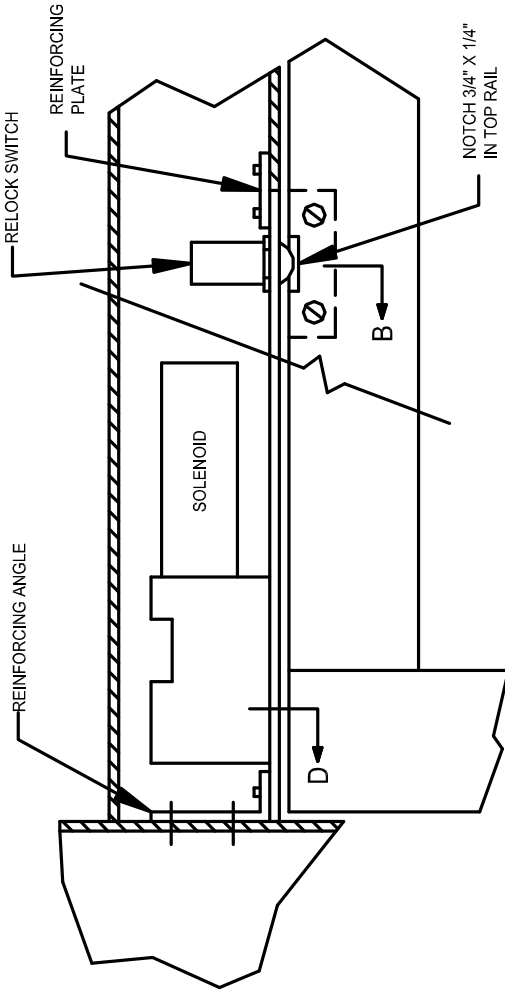

**FIG. A**

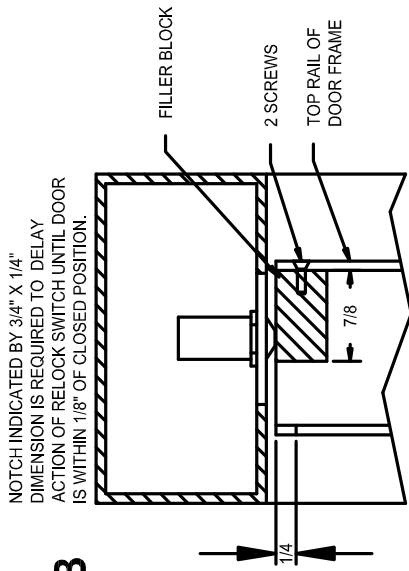

**FIG. B**

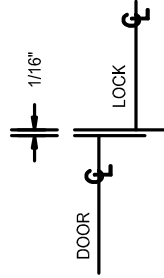

**FIG. D**

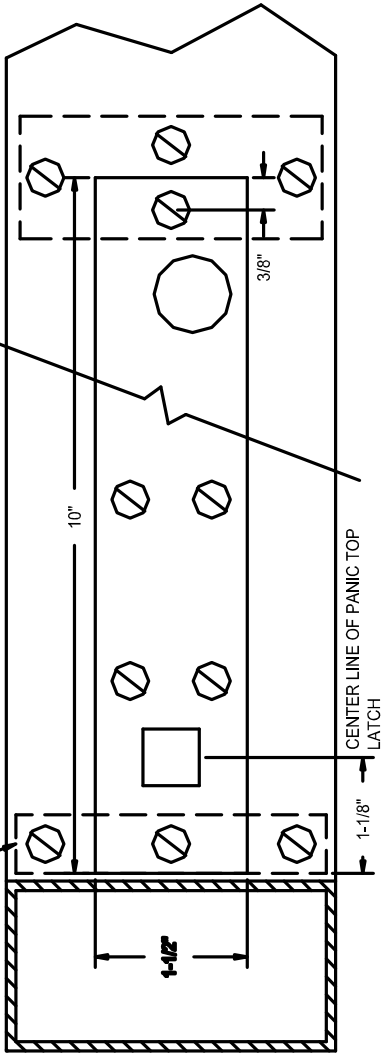

**FIG. C**

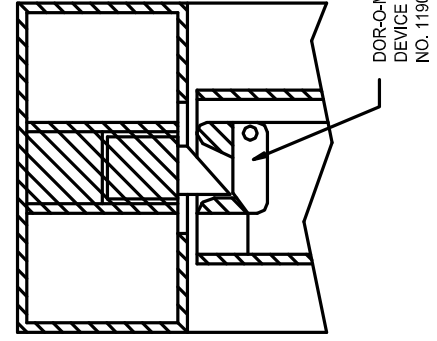

VIEW OF UNDERSIDE OF HEADER  
(CUT-OUT DETAIL)