

SDC SECURITY DOOR CONTROLS

3580 Willow Lane, Westlake Village, CA 91361-4921 • (805) 494-0622 • Fax: (805) 494-8861
 www.sdcsecurity.com • E-mail: service@sdsecurity.com

INSTALLATION INSTRUCTIONS LR100 ELECTRIC LATCH RETRACTION DEVICE KIT (VON DUPRIN)

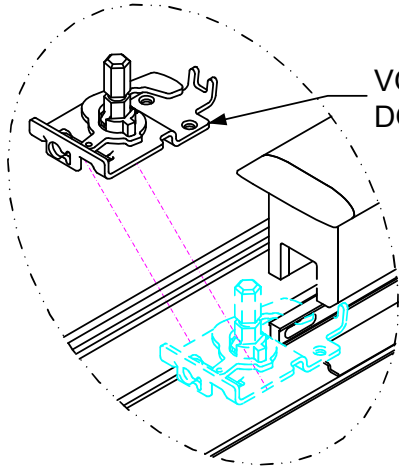

VON DUPRIN MECHANICAL DOGGING ASSEMBLY

Step 1
 Remove Von Duprin installed mechanical dogging assembly.

ELECTRICAL DATA
 24VDC @ 450/180mA
 RED (+) BLK (-)
 PATENT PENDING

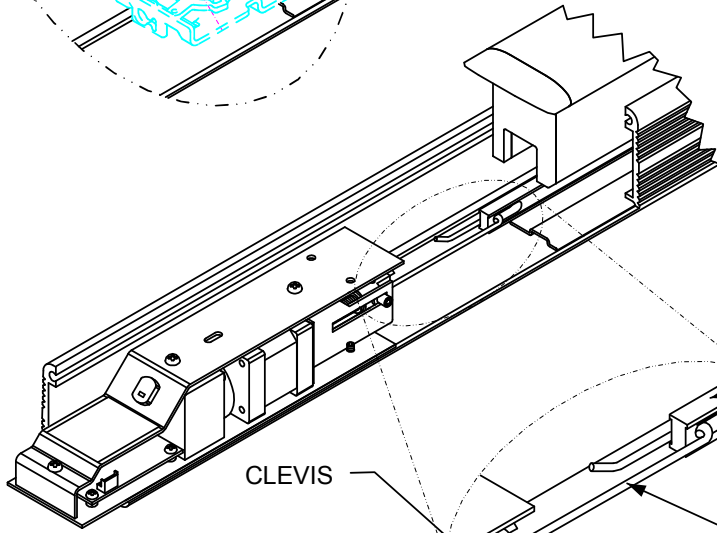

Step 2
 Slide the LR100 Electric Latch Retraction assembly into device and attach the linkage to the latch retraction rod.

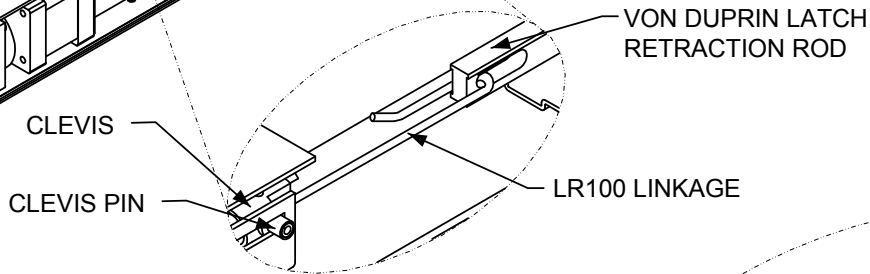

Step 3
 Carefully slide the LR100 assembly back out until the linkage JUST makes contact with the latch retraction rod. Tighten set screws.

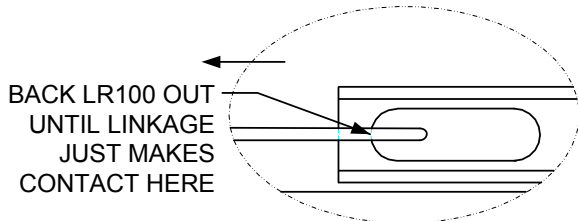

TIGHTEN SET SCREWS TO LOCK DEVICE IN POSITION

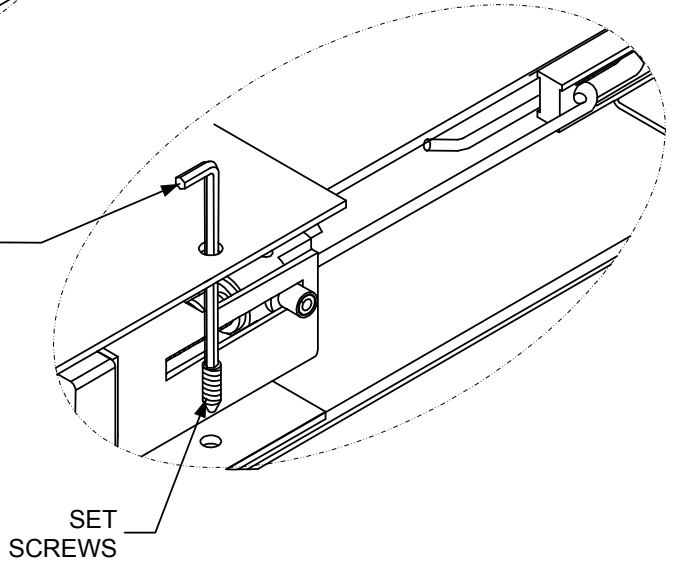

Any suggestions or comments to this instruction or product are welcome. Please contact us through our website or email engineer@sdsecurity.com

**INSTALLATION INSTRUCTIONS
LR-1VD CONNECTING ROD
FOR USE ON VON DUPRIN DEVICES
LESS DOGGING FEATURE**

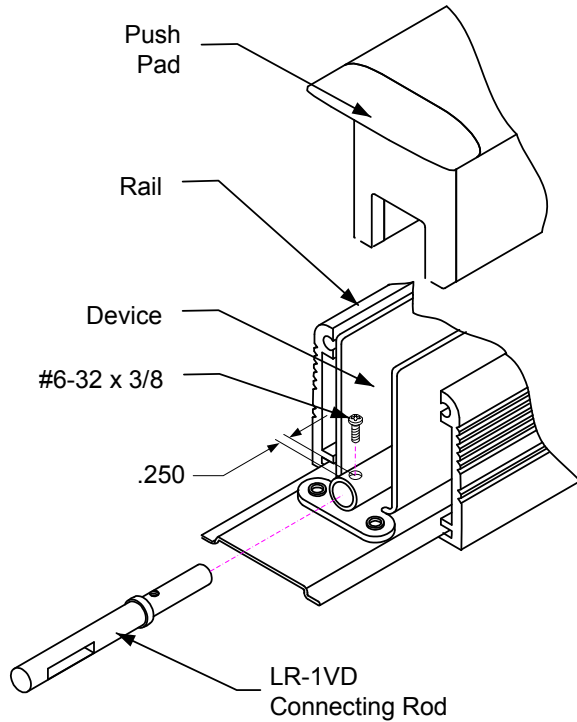

1. Remove the rail and push pad from the device
2. Drill a 5/32" (.156") diameter hole as shown in illustration.
3. Insert the connecting rod provided and fasten in screw

**INSTALLATION INSTRUCTIONS
LR-22VD Hold Down Bracket
FOR USE ON VON DUPRIN
22 SERIES DEVICES**

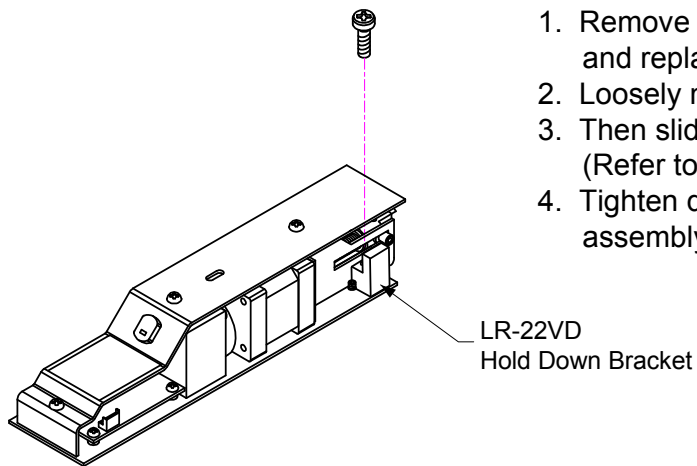

1. Remove a set screw from the ELR base assembly and replace with the hold down bracket provided .
2. Loosely mount the bracket into the base assembly.
3. Then slide the ELR assembly into the device rail (Refer to step 2 & 3 on reverse side).
4. Tighten down the hold down bracket to secure the assembly in the device.