

# SDC Security Door Controls

801 Avenida Acaso, Camarillo, Ca. 93012 • (805) 494-0622 •  
www.sdcsecurity.com • E-mail: service@sdsecurity.com

## INSTALLATION INSTRUCTIONS 410/420 SERIES PUSH SWITCH

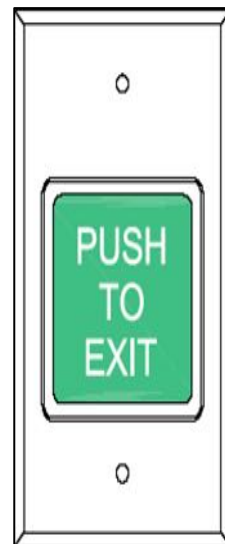

### Electrical Specifications

Contact Type: SPDT (Form C)  
Contact Ratings: 30VDC @ 5 AMPS  
(Resistive)

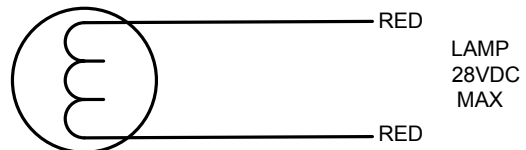
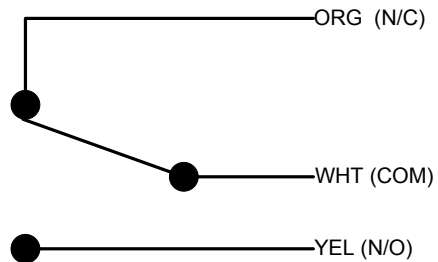

# SDC SECURITY DOOR CONTROLS

3580 Willow Lane, Westlake Village, CA 91361-4921 • (805) 494-0622 • Fax: (805) 494-8861  
 www.sdcsecurity.com • E-mail: service@sdsecurity.com

## INSTALLATION INSTRUCTIONS MODEL 422 PUSH SWITCH



**422GPE**

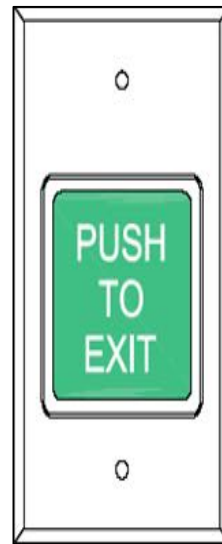

**422NGPE**

### Electrical Specifications

Contact Type: SPDT (Form C)  
 Contact Ratings: 30VDC @ 5 AMPS  
 (Resistive)

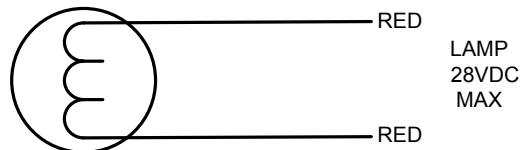
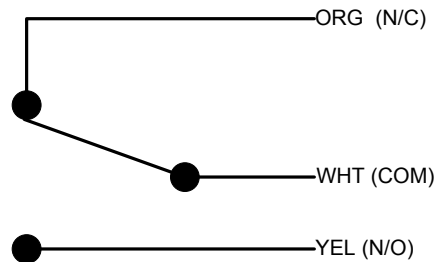

# SDC SECURITY DOOR CONTROLS

801 Avenida Acaso, Camarillo, CA 93012 • (805) 494-0622  
www.sdcsecurity.com • E-mail: service@sdsecurity.com

## INSTALLATION INSTRUCTIONS MODEL 413NU & 423U PUSH SWITCH 1-60 SECOND ADJUSTABLE TIME DELAY

When the button is pressed, the lock releases for 1-60 seconds. If pressed again during the lock release period, the unit will "Retrigger" starting a new release period.

### Electrical Specifications

Input Voltage : 12/24VDC @90ma.  
LED Indicator : 12/24VDC @ 10/20ma  
Output Relay: DPDT  
Max Load : 30VDC @ 5 AMP (Resistive)

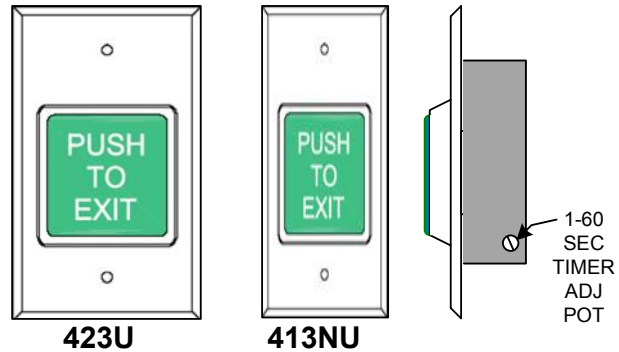

### TYPICAL WIRING

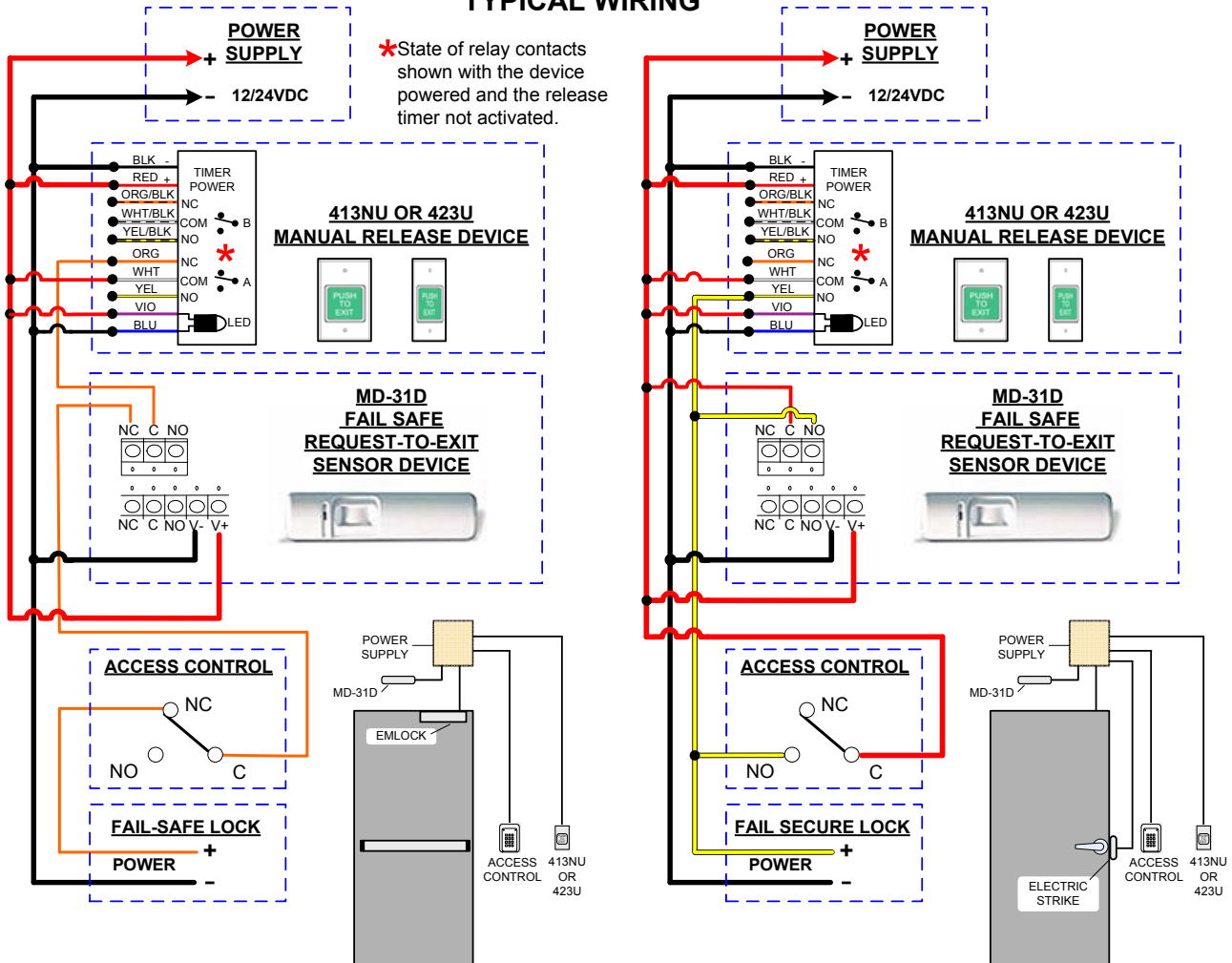

# SDC SECURITY DOOR CONTROLS

801 Avenida Acaso, Camarillo, Ca. 93012 • (805) 494-0622 • Fax: (805) 494-8861

www.sdcsecurity.com • E-mail: service@sdsecurity.com

## INSTALLATION INSTRUCTIONS MODEL 413MN & 423M PUSH SWITCH FIXED 30 SECOND TIME DELAY

This push to exit button is specifically intended for installation on Access Controlled Egress doors as described in the Boca code. A motion detector is the primary means of releasing a magnetic lock on the door. The push to exit button is intended, as a back up means of releasing the lock in the event there is a problem with the motion detector. When the button is pressed, the lock releases for 30-seconds. If pressed again during the 30-seconds lock release period, the unit will "Retrigger" starting a new 30-second lock release period.

### TYPICAL WIRING

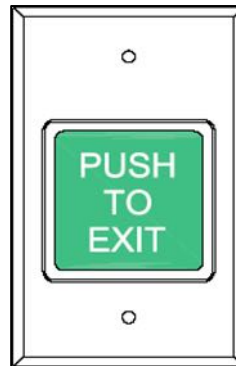
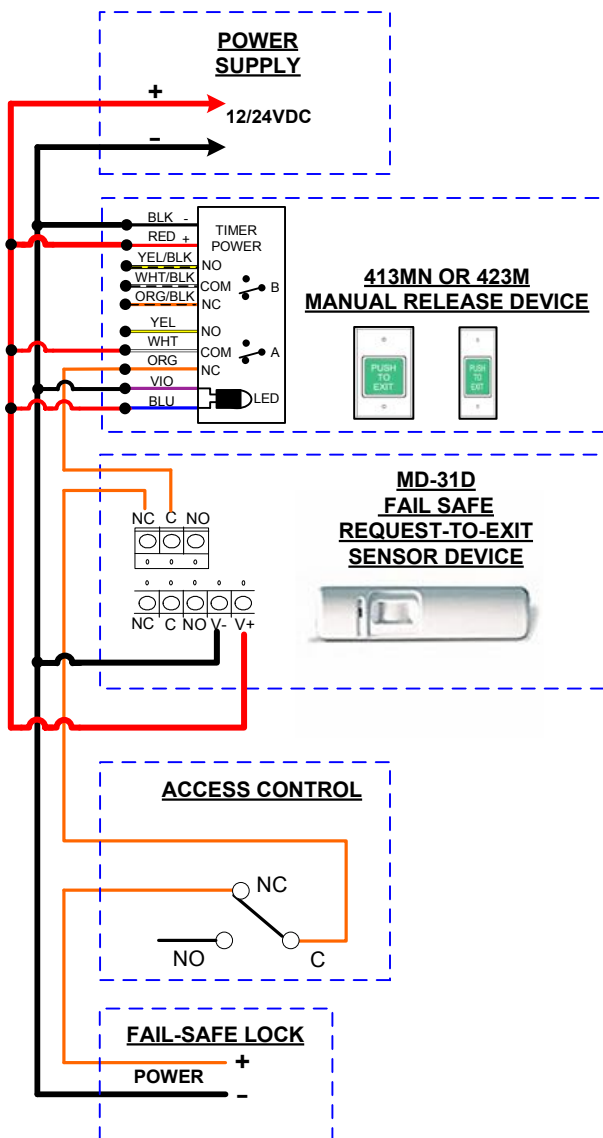

### Electrical Specifications

Input Voltage : 12/24VDC @90ma.

LED Indicator : 12/24VDC @ 10/20ma

Output Relay: DPDT

Max Load : 30VDC @ 5 AMP (Resistive)

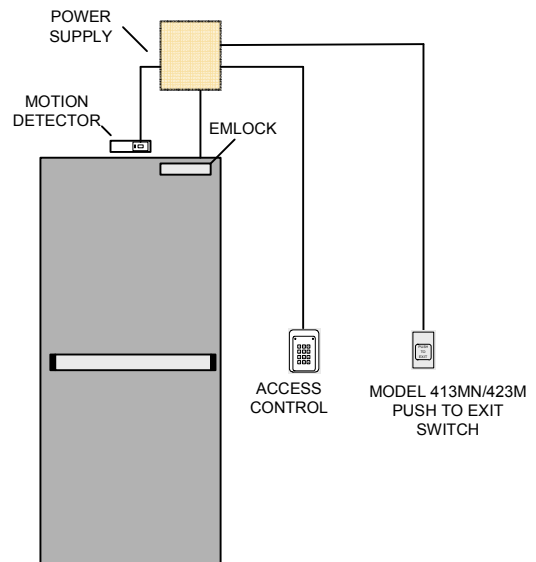

Any suggestions or comments to this instruction or product are welcome. Please contact us through our website or email engineer@sdsecurity.com

# SDC Security Door Controls

801 Avenida Acaso, Camarillo, Ca. 93012 • (805) 494-0622 •  
 www.sdcsecurity.com • E-mail: service@sdsecurity.com

## INSTALLATION INSTRUCTIONS 414 & 424 PUSH SWITCH

424U



414NU

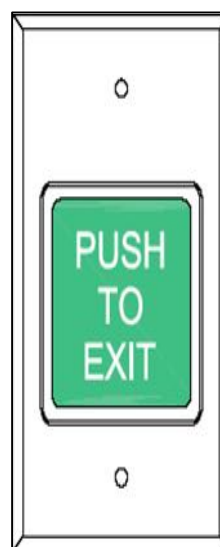

### Electrical Specifications

Contact Type: DPDT (Form C)  
 Contact Ratings: 30VDC @ 5 AMPS  
 (Resistive)

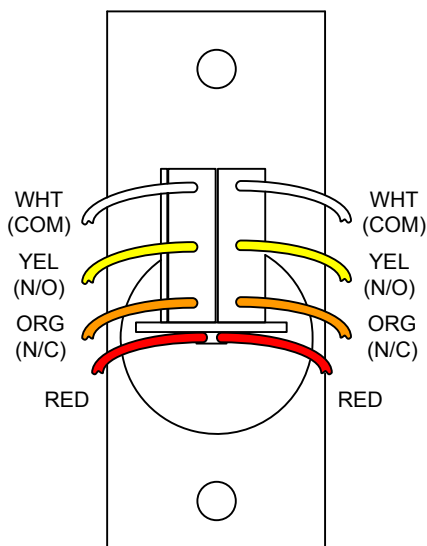
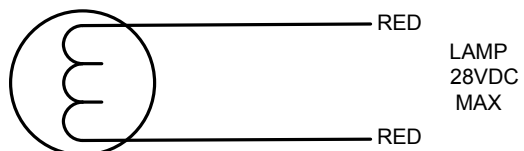

Any suggestions or comments to this instruction or product are welcome. Please contact us through our website or email [engineer@sdsecurity.com](mailto:engineer@sdsecurity.com)

## INSTALLATION INSTRUCTIONS MODEL 415N & 425 ON/OFF PUSH SWITCH

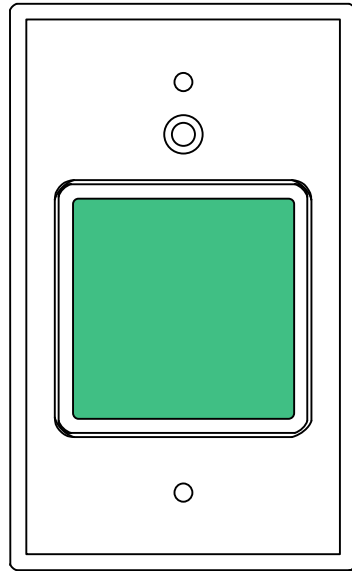

**425**

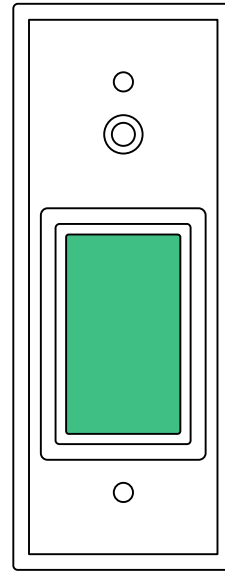

**415N**

### Electrical Specifications

Contact Type: DPDT (Form C)  
 Contact Ratings: 30VDC @ 5 AMPS  
 (Resistive)

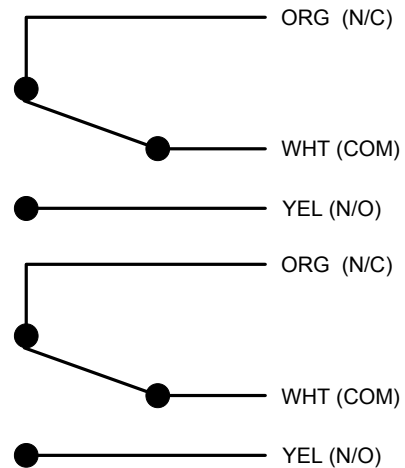
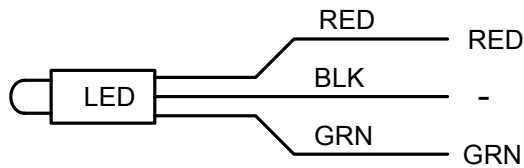

Any suggestions or comments to this instruction or product are welcome. Please contact us through our website or email [engineer@sdsecurity.com](mailto:engineer@sdsecurity.com)

# SDC Security Door Controls

3580 Willow Lane, Westlake Village, CA 91361-4921 • (805) 494-0622 • Fax: (805) 494-8861  
 www.sdcsecurity.com • E-mail: service@sdsecurity.com

## INSTALLATION INSTRUCTIONS MODEL 460 REQUEST – TO – EXIT - SWITCH

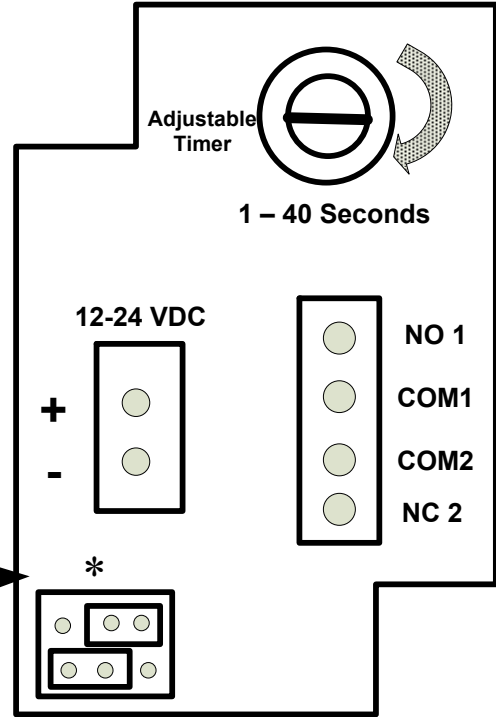

With the jumpers \* as shown the red LED's are on in stand-by and the green LED's turn on when the relay is on.

### Specifications

**Input Voltage:** 12/24VDC

**Current:**

LED On: Idle-60mA, Active 120mA  
 LED Off: Idle-10mA, Active-60mA

**Outputs:**

1 N.O., 1 N.C., 2 Amp @ 30VDC

**Switch Operating Environment**

-40° F to +160°F (-40° C to +70°C)

**Dimensions**

4.5" H x 2.75" W x 1.25" D  
 (11.4 x 7 x 3.2 cm)

Selectable Bi-color Illumination Status  
 Relay Off – Red, Green or None  
 Relay On – Red, Green or None

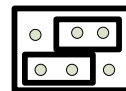

**Red On – Standby  
 Green On – Relay Action**

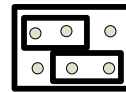

**Red On – Relay Active  
 Green On - Standby**

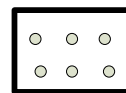

**Red Off  
 Green Off**