

SDC Security Door Controls

801 Avenida Acaso, Camarillo, Ca. 93012 • (805) 494-0622 •
www.sdcsecurity.com • E-mail: service@sdsecurity.com

INSTALLATION INSTRUCTIONS 350 NARROW LINE EMLOCK

Retrofits Discontinued Locknetics 350+
Provides Superior Architectural Appearance

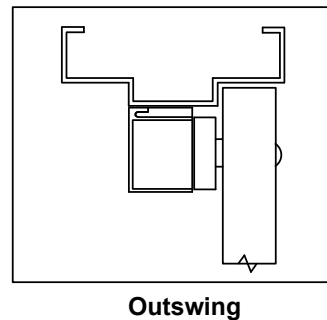
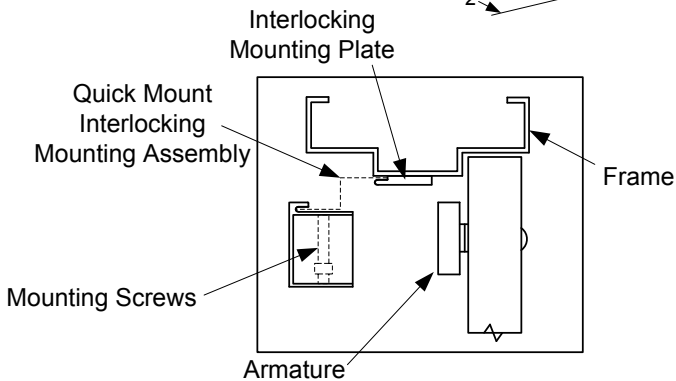
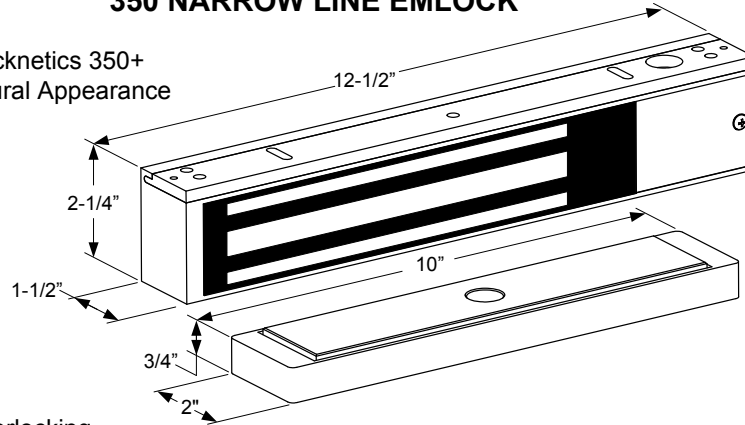

Electrical Instructions:

Use properly fused U. L. Listed Power Supply

Do not install a diode in parallel with any magnetic lock. A diode will cause a delay when releasing the door and residual magnetism to occur.

Access controls and/or release contacts must be located in series with the positive (+) power lead of the EmLock.

Any low voltage condition will cause erratic operation of the optional board sensor.

Although SDC recommends the use of a Regulated DC power supply. A significant voltage drop will occur when using a full wave bridge rectifier.

Installation Location – Indoor Dry use only

Electrical Specifications:

Dual Voltage 12 or 24VDC

Power Consumption 560mA@12VDC
309mA@24VDC

DS Door Status Sensor SPDT, 250mA@24VDC
LS Lock Status Sensor SPDT, 1A@24VDC
Resistive

Supplied Mounting Hardware

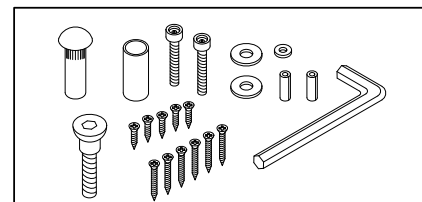

SIGNALING



PATENT NO. 5,376,910

LISTED

1. Fold template as indicated on dotted line. For single doors locate template against the door and header on the lock jamb side of the frame.
2. Mark and drill holes as indicated by the template.

STEPS 1 & 2

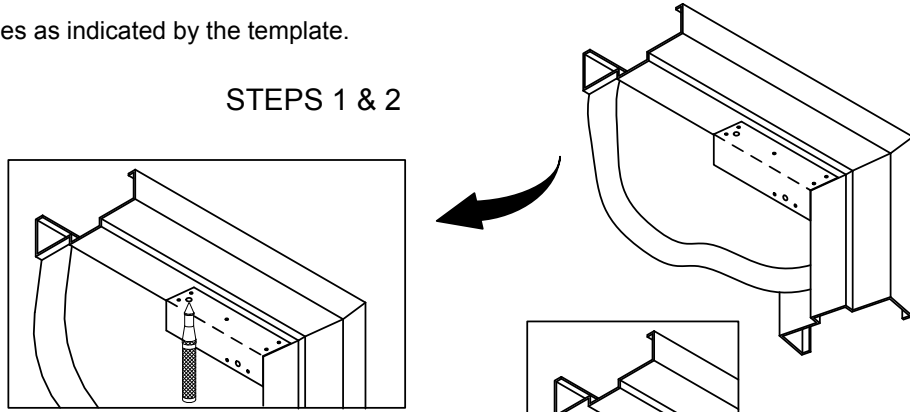

3. Mount armature to door.

STEP 3

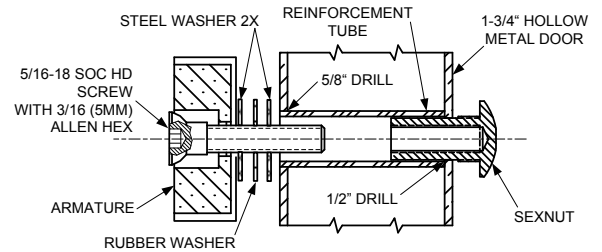
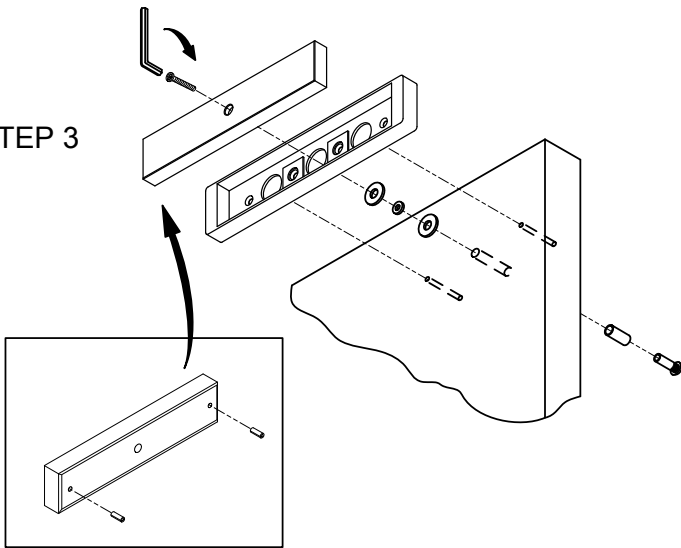

HOLLOW METAL DOOR

From Sexnut side of door, drill exactly 1/2" hole thru one metal thickness only. From Armature side of door, drill 5/8" hole to insert reinforcement tube. Press in sexnut and reinforcement tube all the way and mount armature to door using hardware provided.

4. Install magnet onto the header with the magnetic stripes towards the door side of the stop. Assure that the magnet and armature line up properly, then tighten down ALL mounting screws.

STEP 4

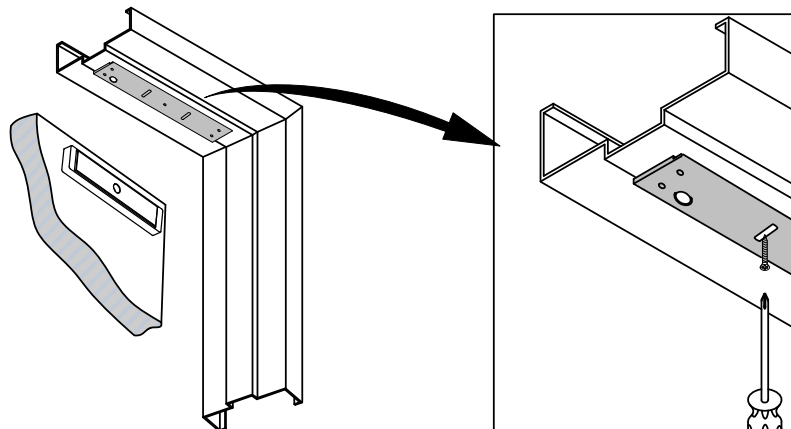

5. Holding the magnet housing at each end, engage the entire length of the interlock detail, by pushing towards the door. Tap with a soft hammer to ensure proper alignment and engagement.

CAUTION: The lock body must be held in place until secured with mounting screws. Secure socket head screws provided inside the housing at each end. Start screws into threads carefully to avoid stripping the threads. Check alignment and tighten screws. Pull wires through frame, mounting plate and magnet housing

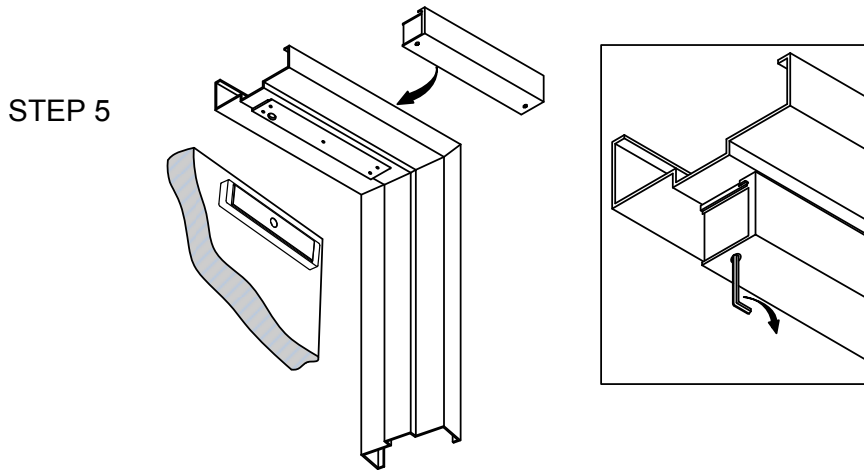

6. Select jumper position for 12VDC or 24VDC. Connect power to magnetic lock.

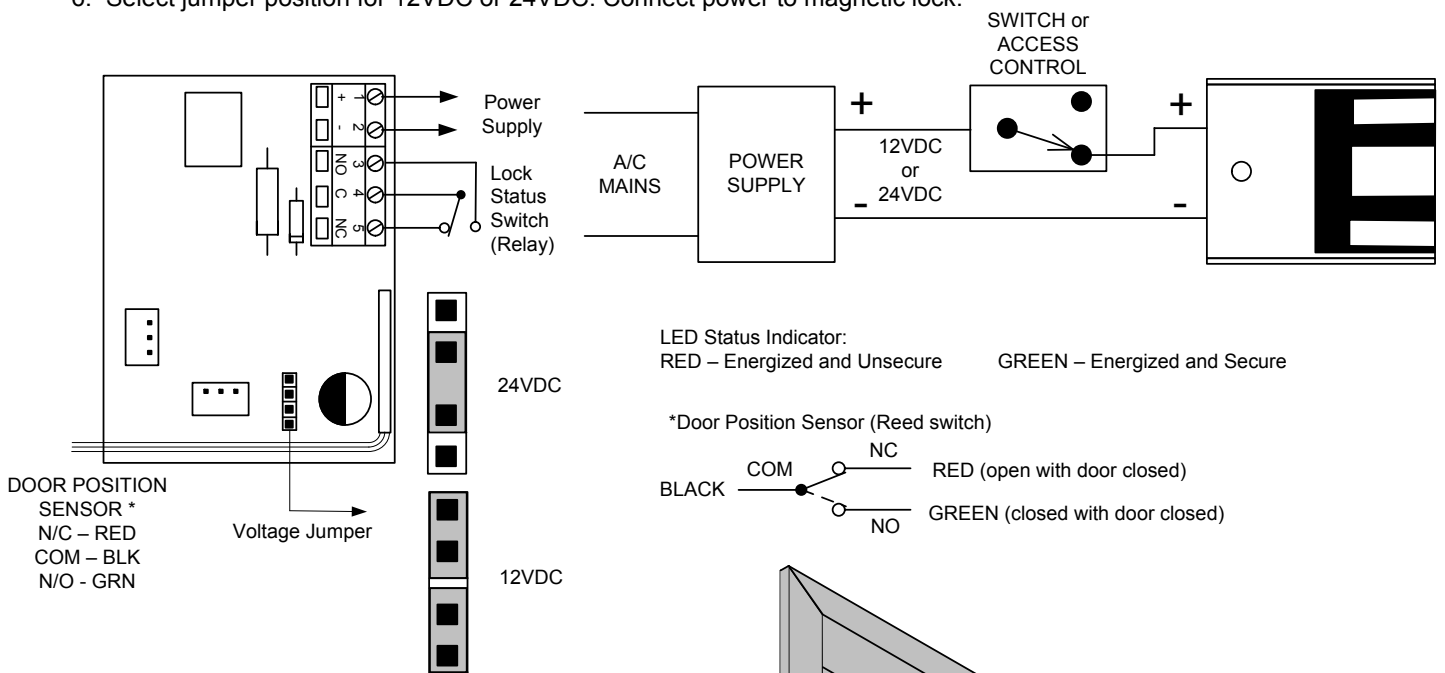

7. Test operation. When all is operating properly, tighten all screws.

To maintain surface plating from corrosion:

- Do not touch the lock face with your hands.
- Clean lock face with Scotch-Brite pad by 3M (do not use sandpaper).
- Apply a thin film of rust inhibitor (LPS-3) on lock face.
- Repeat application on armature plate.

