

MC-HD176/24 Maglock for Explosion Proof Environment
UL-UL Certified for Class 1 Div 2 All Groups A, B, C, D
Push and Pull Sides Installation Instructions

**IMPORTANT! READ THOROUGHLY BEFORE ATTEMPTING INSTALLATION.
DO NOT DAMAGE OR MARK MAGNETIC LOCK OR ARMATURE FACE-MAY REDUCE HOLDING EFFICIENCY.**

NOTE: THIS PRODUCT IS INTENDED TO BE USED IN CLASS 1, DIVISION 2 HAZARDOUS LOCATIONS. THE FOLLOWING GUIDELINES MUST BE OBSERVED TO REDUCE THE RISK OF FIRE EXPLOSION.

All national and local codes must be followed in the installation of the magnetic lock assembly. For code interpretation, consult a local code authority.

This unit must be connected to a NEC (National Electric Code, NFPA 70) Class 2 Supply Circuit rated for 24 VDC with a current output of 0.25 amperes and output power of 6 watts. Operating temperature for the magnetic lock will not exceed 185° F (85° C). Maximum ambient temperature is not to exceed 104° F (40° C).

For supply connections, use a suitable wire with a minimum insulation temperature rating of 167° F (75° C).

To reduce the risk of the ignition of hazardous atmosphere, disconnect the magnetic lock assembly from the supply circuit before opening the magnetic lock housing. Keep the unit properly sealed while in operation. To reduce the risk of fire or explosion, do not install the unit where the operating temperature exceeds the ignition temperature of the hazardous atmosphere.

This unit is intended to be used in the following atmospheres: Acetone, Ammonium Hydroxide, ATSM fuel C, Benzene, Methyl-Ethylketone, Diethyl-Ether, 2-Nitropropane, Ethyl-Acetate, Furfural, Normal Hexane, Methyl Alcohol

Maglocks.com

See Figure 1 elevation profiles to determine mounting application requirements for each individual application.

NOTE: A 2-1/2" (64 mm) REVEAL IS REQUIRED TO ASSURE RIGID MOUNTING OF THE 176-HD SERIES MAGNETIC LOCK ASSEMBLY.

STEP 1. Mark door(s) according to armature template and dimensions on reverse side.

STEP 2. Drill and prep holes in door per armature template on reverse side.

STEP 3. Gently tap (2) 3/16" (5 mm) diameter spring pins into rear side of armature(s).

STEP 4. Insert one (1) spring washer over 5/16"-18 "special" shoulder screw, insert screw through armature. Add three (3) conical spring washers and one (1) flat washer over shoulder screw. See Figure 2 - details for each type of installation. All parts must be assembled properly before installing armature to the door. Install the complete armature assembly on the door per Figure 2 details.

STEP 5. Tighten shoulder screw(s) securely with allen wrench. (Do not overtighten.)

NOTE: ALL ARMATURES ARE NORMALLY EQUIPPED WITH A PERMANENT MAGNET ON ONE END. BE CERTAIN TO INSTALL ARMATURE SO MAGNET LINES UP WITH MAGNETIC SWITCH INSIDE HOUSING OF MAGNETIC LOCK ASSEMBLY. SEE FIGURE 3.

STEP 6. Mark frame per magnetic lock template and dimensions on reverse side.

STEP 7. Remove housing cover of Magnetic Lock Assembly.

STEP 8. Drill and prep frame per "D" of Magnetic lock template, attach Magnetic Lock Assembly to the frame using either (2) #14 sheet metal screws or (2) 1/4"-20 machine screws and external tooth lock washers, tighten only enough to hold the unit in place. (If filler plate is used, assure that the screws go through both the filler plate and the door frame.

STEP 9. Drill 7/8" (22 mm) diameter hole thru filler plate and frame per template for wiring harness.

STEP 10. Make all electrical connections per applicable wiring diagrams enclosed. Use wire nuts, crimp connectors or solder to assure good connections.

STEP 11. Energize Magnetic Lock Assembly; Adjust assembly so door is snug against door stop, tighten (2) preliminary screws securely.

STEP 12. De-energize system. Using mounting plate as template, drill-#21 drill and tap for 10-32 screws (minimum (2) places). (See Magnetic Lock Template) Install screws and tighten securely. Re-energize system, recheck alignment of Magnetic Lock Assembly to Armature by opening and closing door(s).

STEP 13. Install Magnetic Lock housing cover.

- A. For THRU BOLT mounting in hollow metal door(s) drill 11/32" (9 mm) DIA. hole thru door, enlarge hole in outside face to 1/2" (13 mm) DIA.
- B. For THRU BOLT mounting in solid core wood door(s), drill 11/32" (9 mm) DIA. hole thru door(s), enlarge hole in outside face to 1/2" (13 mm) DIA. 1" (25 mm) deep.
- C. For REINFORCED DOOR (Minimum 3/8" (10 mm) thickness) drill and tap thru reinforcement for 5/16-18 screw.
- D. Drill for No. 14 sheet metal screws or drill and tap for 1/4"-20 machine screws.
- E. 1/2-14 NPT, Drill 7/8" (22 mm) DIA. hole thru filler (if used) and frame in either of locations marked (E) for rigid conduit containing wiring harness. Use filler plug in location not used.
- F. Using actual Magnetic Lock as template, drill and tap per STEP 12 of installation instructions.

NOTE: FOR MACHINE SCREW MOUNTING; REINFORCEMENT AND STRUCTURING ARE REQUIRED TO WITHSTAND A 600 LB (272 KG) LOAD. CLEARANCE HOLES FOR FILLER PLATE TO BE SPOTTED AT JOB SITE. CAUTION: "DO NOT ATTACH MOUNTING PLATE TO FILLER PLATE ONLY"

MAGNETIC LOCK MOUNTING TO FRAME FIGURE 1

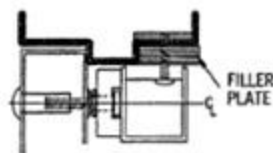


FIGURE 1B
WITH SERIES 178 FILLER PLATE

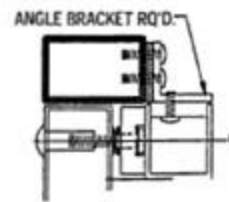


FIGURE 1C
WITH 179 SERIES ANGLE BRACKET

ARMATURE MOUNTING TO DOOR(S) FIGURE 2

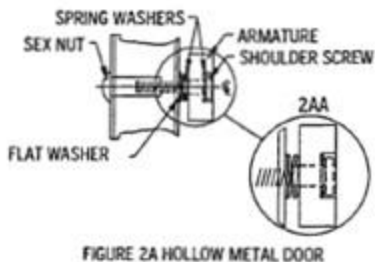


FIGURE 2A HOLLOW METAL DOOR

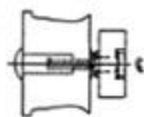


FIGURE 2B WOOD DOOR

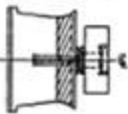


FIGURE 2C REINFORCED DOOR

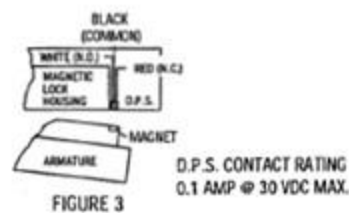


FIGURE 3
WIRING FOR D.P.S. (DOOR POSITION SWITCH).
DRAWING SHOWS DOOR IN OPEN POSITION

ELECTRICAL SPECIFICATIONS:
 CURRENT DRAW: 0.50 AMPS @ 12 VDC
 0.25 AMPS @ 24 VDC
 WIRE COLOR CODE: RED/RED
 (NON-POLARIZED)
 HOLDING FORCE: 600 LB (272 KG)

NOTE: Use with Underwriters Laboratories Listed (ULC/UL) Compatible Power Supply

*NOTE: NOT TO SCALE

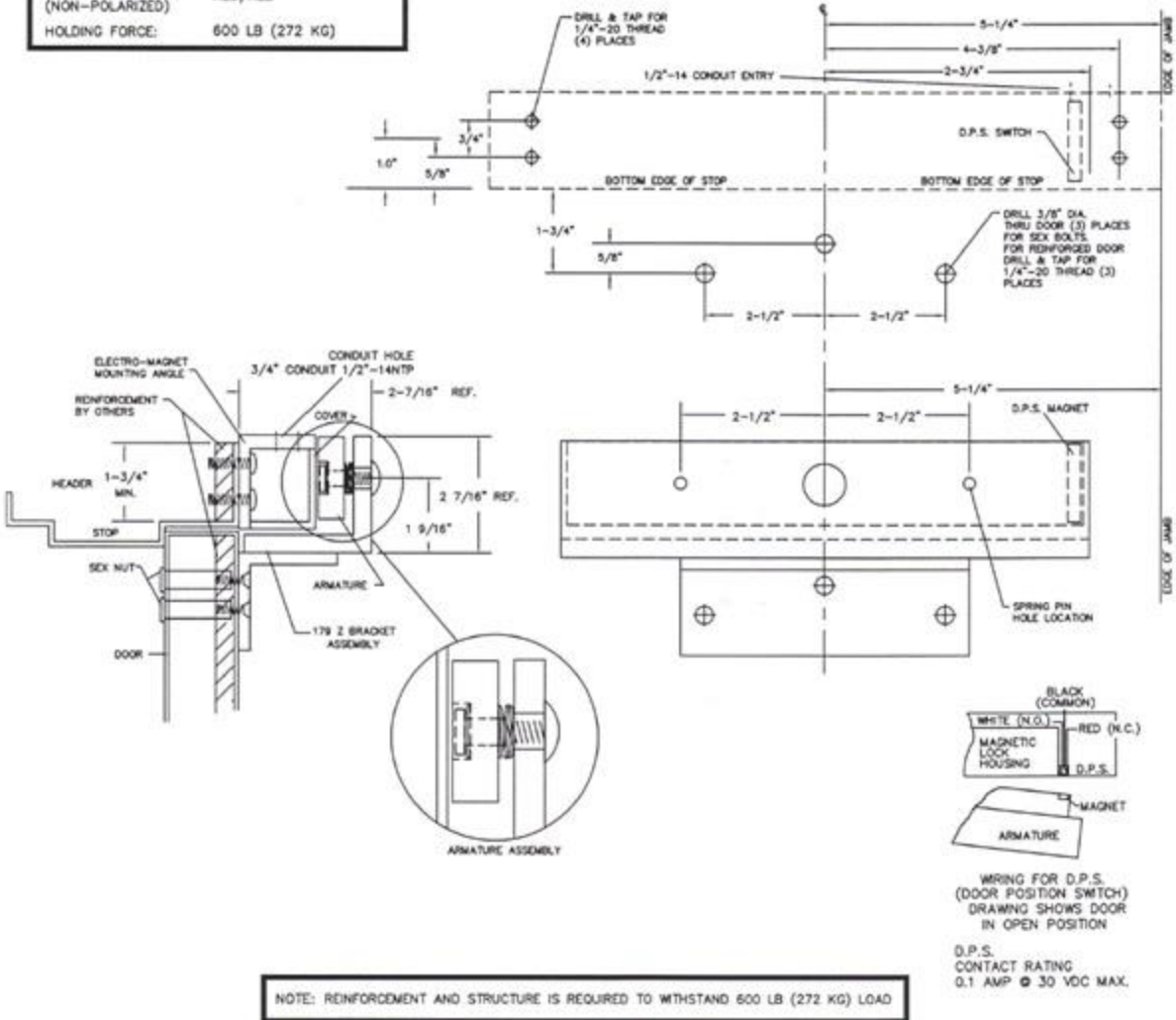
Installation Details for MC-HDZB176/24 with Z Bracket

PULL SIDE MOUNTING (in-swing door)

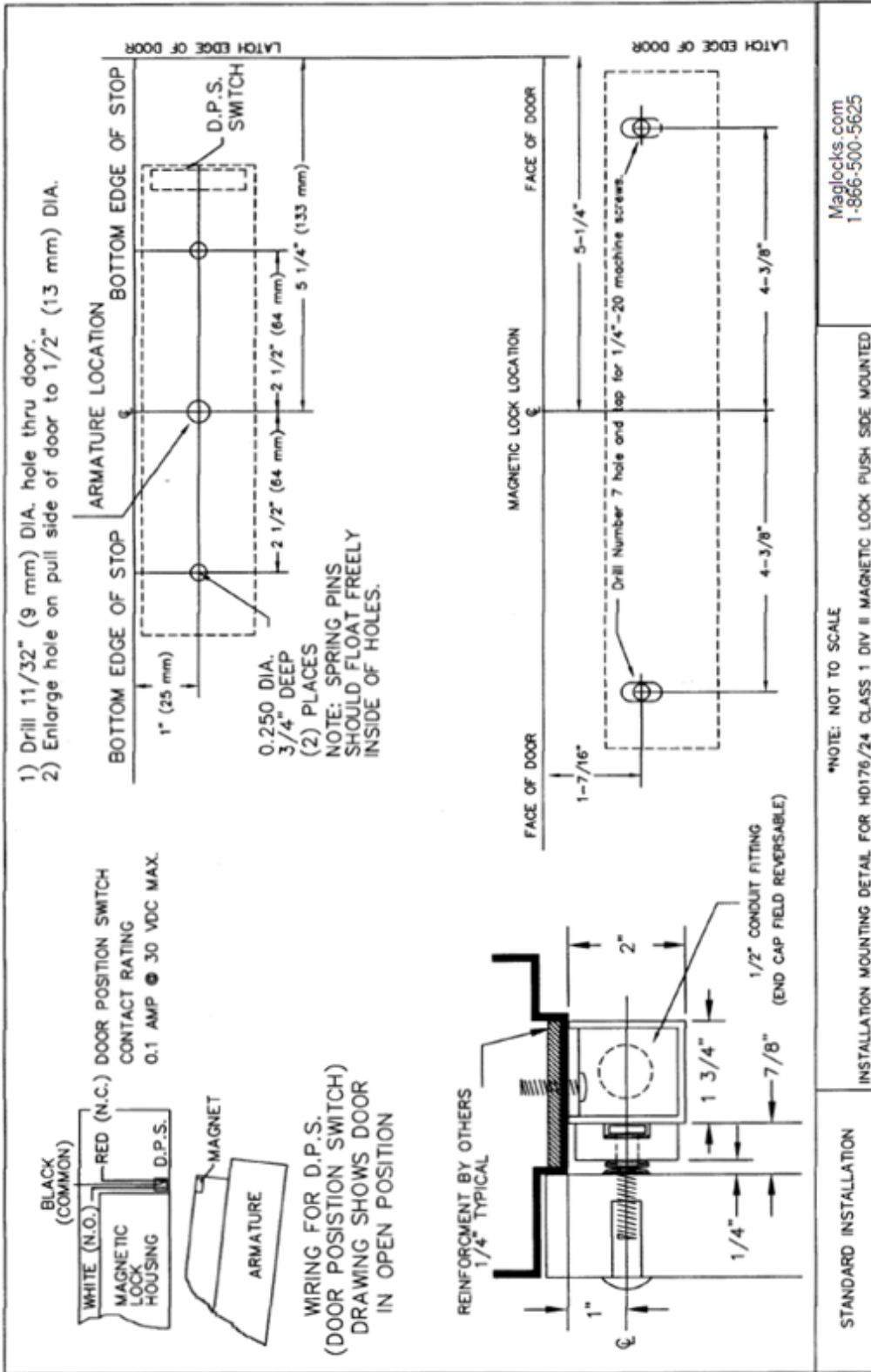
Maglocks.com

ELECTRICAL SPECS:	0.50 AMPS @ 12 VDC
CURRENT DRAW:	0.25 AMPS @ 24 VDC
WIRE COLOR CODE: (NON-POLARIZED)	RED/RED
HOLDING FORCE:	600 LB (272 KG)

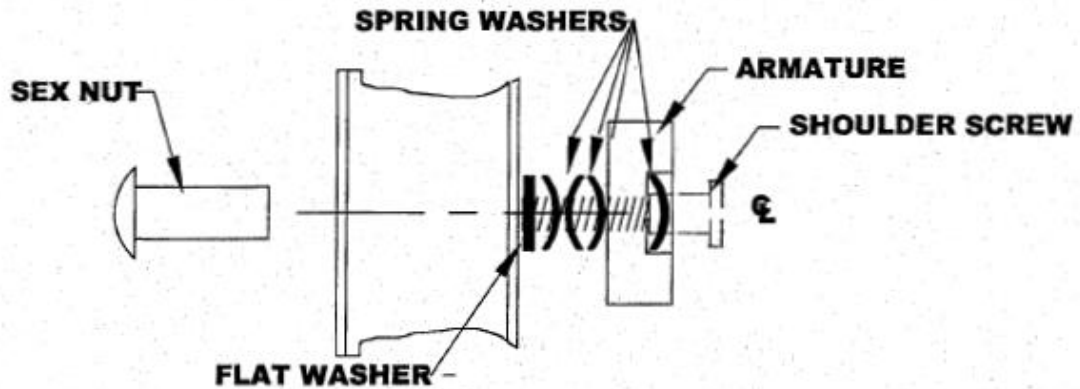
INSTALLATION TEMPLATE WITH "Z" BRACKET OPTION PULL SIDE MOUNTING (STANDARD)



Installation Details for MC-HD176 PUSH SIDE MOUNTING (outswing door)

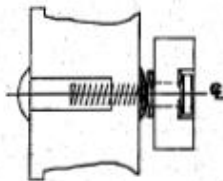


**Armature bolt - washers arrangement
STANDARD INSTALLATION**

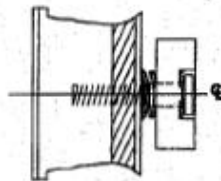


**FIGURE 2A
HOLLOW METAL DOOR**

**ARMATURE MOUNTING TO DOOR(S)
FIGURE 2**



**FIGURE 2B
WOOD DOOR**



**FIGURE 2C
REINFORCED DOOR**

***NOTE: NOT TO SCALE**

www.Maglocks.com

1-866-500-5625

sales@maglocks.com