



# CL4500 - Installation Instructions

Views: 169



## Box Contents

Check the contents of the box are correct according to the model

	4510	4520
1 Front Plate	✓	✓
2 Back Plate	✓	✓
3 Lever Handles	✓	✓
4 Gaskets	✓	✓
5 Sprung Spindle (x1)	✓	✗
6 Spring Spindle (x3) 15/26/60mm (1/2" / 1 1/32" / 2 3/8")	✗	✓
7 1.5vAA Batteries (x4)	✓	✓
8 Mortice Latch, Strike and 4 screws	✓	✗
9 Fixing Bolts x 3 incl. spare	✓	✓
10 Latch Support Post	✓	✗
11 Allen Keys	✓	✓
12 Euro profile cylinder escutcheons (x2)	✗	✓
13 Double euro profile cylinder & 3 keys	✗	✓
14 Cable Connections for REM1 and REM2	✓	✓
15 Front Plate Cylinder Keys	✓	✓
16 Front Plate Cylinder Cover	✓	✓
17 Classroom Function Tailpiece	✓	✓
18 Mortice Lock	✗	✓

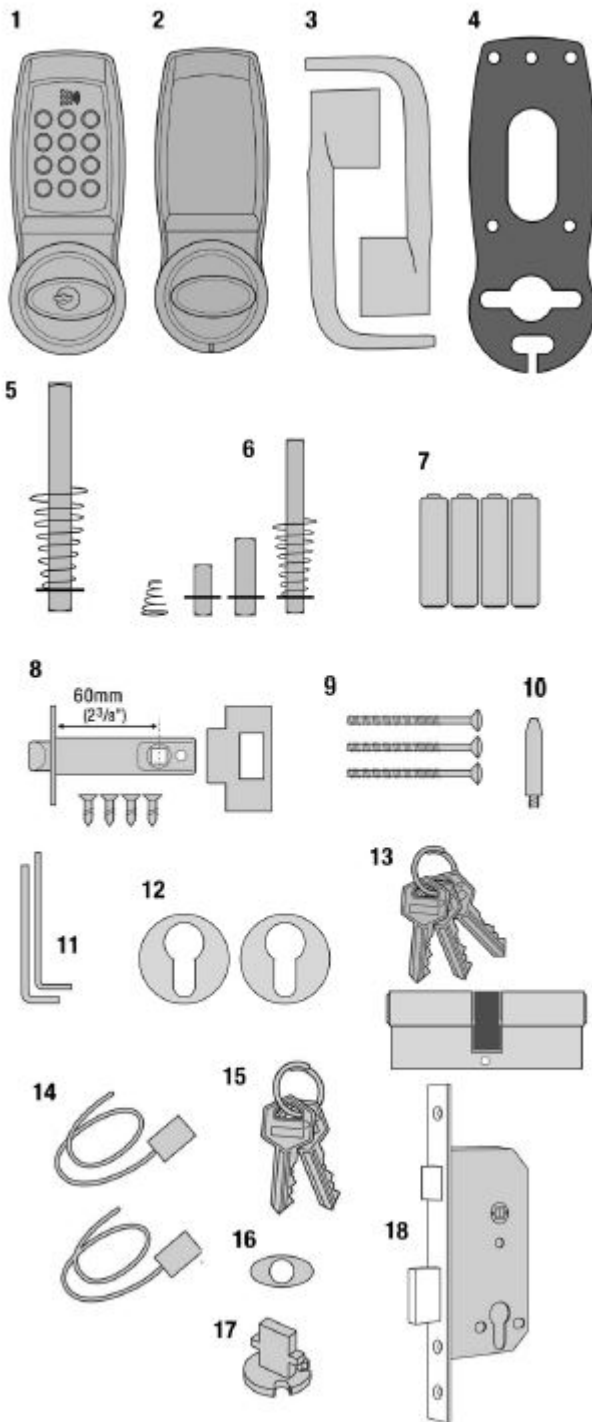

**This box should also contain the installation template and getting started guide.**

## Tools Required

- Power Drill
- Drill bits CL4510 10mm ( $\frac{3}{8}$ " ) & 25mm (1")
- Drill bits CL4520 10mm ( $\frac{3}{8}$ " ), 12mm ( $\frac{15}{32}$ " ), 16mm ( $\frac{5}{8}$ " ) & 20mm ( $\frac{25}{32}$ " )
- Hammer / mallet
- Philips screwdriver
- Chisel 25mm (1")

- Stanley knife
- Adhesive tape, pencil, bradawl, tape measure
- Pliers and hacksaw for cutting bolts

## Operations Check

You should familiarise yourself with the operation of the lock and check that all the parts work properly.

Remove the battery cover from the back plate and install the 4 x AA cells supplied.

Connect the cables from the front plate and back plate. A BEEP should be heard when you do this. If no BEEP is heard then check that the batteries are correctly installed.

Place the long spindle in the front plate socket and using finger grip only, test that the spindle is easily moved 80° in both directions.

Leave socket in the centred position.

Enter the factory Master Code #12345678.

The keypad will flash blue and the spindle should not turn as before. After 5 seconds the keypad will flash red and the spindle should turn easily again. This confirms that the clutch engaged correctly when the code was entered

**N.B.** When the Master Code is entered 3 times consecutively without performing a programming function, a penalty time of 30 seconds is activated.

Disconnect the cables.

## Special Fixing Note

### Remote Release Option

Cables are provided for the **REM 1** and **REM 2** terminals on the circuit board.

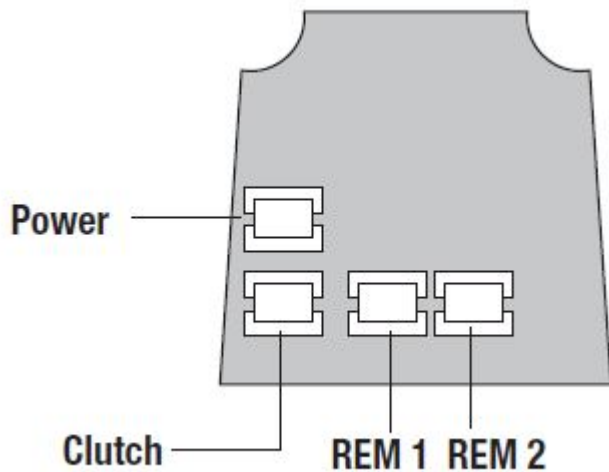

**REM 1** is for connection to a reception desk push button or a door intercom system. Pressing the button will cause the keypad to flash blue on the lock and release the lock for the pre-set time.

**REM 2** is for connection to the building alarm system to release a door in an emergency. This allows rooms, wards, offices to be easily checked to ensure that no person is trapped or overlooked during an emergency evacuation. When activated REM 2 will maintain the unlocked condition for 30 minutes, the keypad will flash red and BEEP during this time. The lock will automatically lock again after 30 minutes. If necessary Program 7 can be used to re-lock before the end of the 30 minutes. REM 1 and REM 2 do not require additional power. They are normally open contacts requiring a momentary or maintained signal to close.

## Functions

### CL4510 Latch Function

Outside handle turns freely without operating the latchbolt. When the code is entered the keypad will flash blue and the handle will retract the latchbolt. The latch automatically locks the door when closed. The key will open the door without the code.

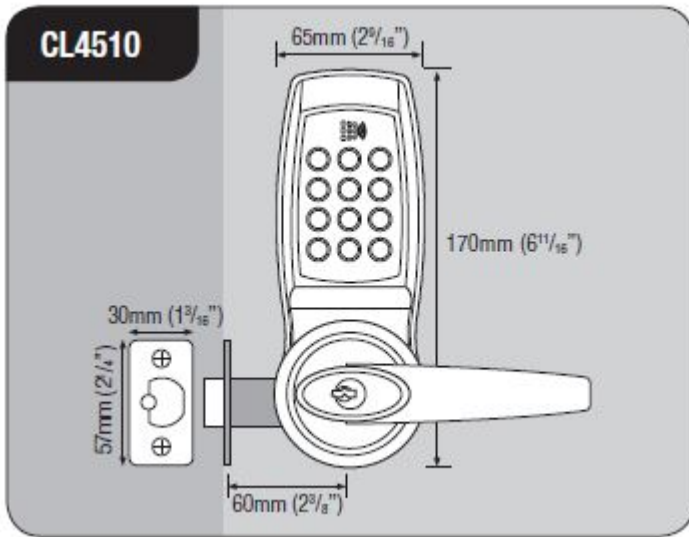

## CL4520 Anti-Panic Lock Function

Outside handle and key functions as before. Lock case key will double-throw the deadbolt, retract the deadbolt and retract the latchbolt without the code. When deadbolt is thrown it denies access by code. The anti-panic feature allows the inside handle to simultaneously retract the latchbolt and the deadbolt preventing people being accidentally locked in.

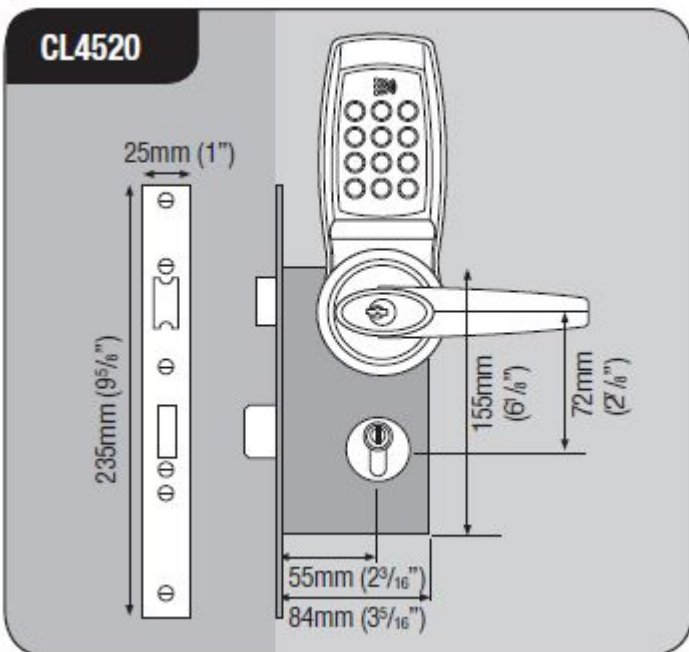

## Installation of CL4510 Locks

**Take time to be precise and finish the job quicker.** Installation holes must be drilled in exactly the correct positions and precisely at right angles to the door surface. Lock components must be vertically and horizontally accurate in relation to each other and to the door.

**Wedge the door firmly to prevent movement whilst drilling and chiselling.**

1. Lightly mark a height line on the edge and both faces of the door and on the door jamb, to indicate the top of the lock when fitted. Crease the template along one of the dotted lines 60mm (2 3/8") or 70mm (2 3/4") latch and tape it to the door with the top in line with the height line. Mark the holes to be drilled. Mark the centre line of latch on to the door edge. Apply the template to the other side of the door precisely against the height line and the centre line of latch mark. Mark the holes to be drilled again. (See diagram A).

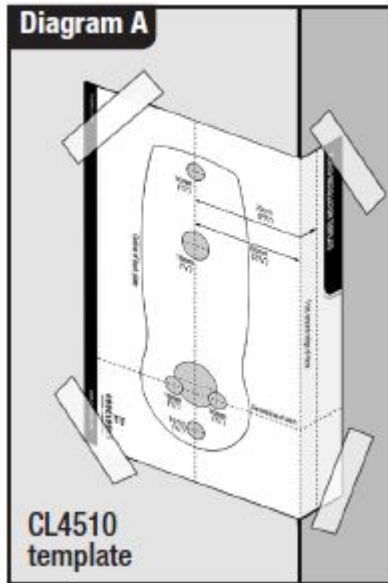

2. Keeping the drill level and straight, drill a 25mm (1") hole in the centre of the door edge to accept the latch.

3. Keeping the drill level and straight, drill the holes in the door face. Drill from both sides of the door to increase accuracy and to avoid damage to the other side when a drill goes right through.

4. Put the latch into the hole and, holding it square to the door edge, draw around the faceplate. Starting with the top and bottom cuts, chisel a rebate to allow the latch face to flush with the door edge. (See diagram B).

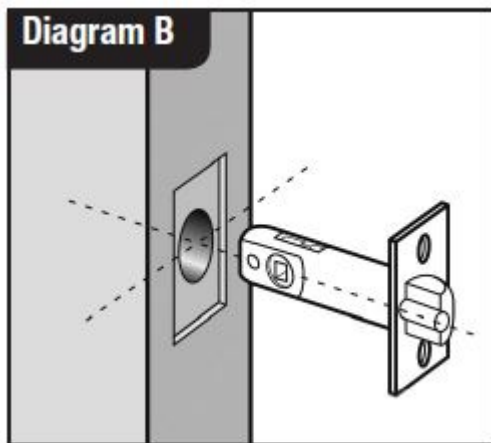

5. Fix the latch with the wood screws, with the bevel toward the door frame.

6. Fit the latch support post on the inside of the front plate, in hole A for a right hand hung door and hole B for a left hand hung door. (See diagram C).

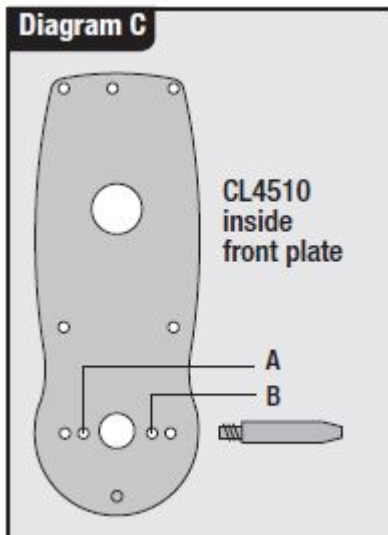

7. Fit the self-adhesive gaskets to the front and back plates. The gaskets provide friction against the door so that it is not necessary to over-tighten the fixing bolts to provide stability.
8. Cut the fixing bolts to correct length. Measured from beneath the bolt head, the length should be the door thickness, plus approximately 15mm ( $\frac{3}{5}$ " ) to the nearest cutting point of the bolt. **N.B.** Always cut the bolts at one of the cutting points so as not to damage a thread. Use the cutting edges of pliers to crimp strongly several times around the selected cutting points. The surplus end should break off quite easily.
9. Put the spindle into the latch with the spring on the front plate side of the door.
10. Remove the battery cover from the back plate, and remove the battery pack. Apply the front plate over the spindle, passing the latch support post through the latch and the cable through the door. Place the back plate over the spindle, pull the cable through, and screw the fixings bolts through to the front plate.
11. Using the inside handle boss check that the spindle moves freely, and that the latch retracts and projects smoothly. If it is tight, loosen the fixing bolts slightly and adjust the position of the back plate until the spindle will turn freely. Tighten the fixing bolts. Test the spindle again. Do not over-tighten the bolts as this may cause the door to distort and affect the lock function.
12. Connect the cables, storing any excess cable with the door. Then install the batteries.
13. Fit the cylinder cover and outside handle to the front plate.
14. Fit the inside handle to the back plate.
15. The inside handle will now retract the latchbolt. The outside handle will turn freely without retracting the latch. Enter the factory Master Code #12345678. The keypad will flash blue and the outside handle will now retract the latch.
16. **Fitting the strike plate** Position the strike plate on the door frame so that the aperture lines up with the flat of the latchbolt, and NOT the plunger. Mark the positions of the fixing screws and draw around the aperture of the strike plate. Chisel out the aperture to 15mm ( $\frac{3}{5}$ " ) deep to receive the latchbolt. Fix the strike plate to the surface of the frame using only the top fixing screw. Gently close the door and check that the latchbolt enters the aperture easily, and is held without too much 'play'. When satisfied, draw around the outline of the strike plate, remove it and cut a rebate to enable the strike plate to lie flush with the

surface. Re-fix the strike plate using both screws. **N.B.** The plunger beside the latchbolt deadlocks it to protect against manipulation or 'shimming'. The strike plate must be accurately installed so that the plunger CANNOT enter the aperture when the door is closed, even when it is slammed shut.

## Installing the Anti-Panic CL4520 Mortice Lock

**IMPORTANT** The Anti-Panic Mortice Lock has features which are not found in most locks and so it is recommended that you familiarise yourself with them.

The hand of the latchbolt is changed by removing the three screws holding the faceplate and reversing the latchbolt. Insert the cylinder centrally in the lock case and fix in position with the long bolt through the faceplate. Using the key it should be possible to double-throw the deadbolt, retract the deadbolt, and retract the latchbolt.

The latchbolt follower is in two parts, with two set screws visible in each part. **Determine which side of the lock will be the outside and remove the set screws from that side. DO NOT remove the set screws from both sides.** The outside handle will now retract the latchbolt but not the deadbolt.

The inside handle will now simultaneously retract the latchbolt and the deadbolt if it is thrown.

This safety feature ensures that it is not possible to accidentally lock someone in a room by throwing the deadbolt from outside.

Throwing the deadbolt will deny access to code users when appropriate.

All door locks should be installed with a degree of precision to ensure that all components are horizontally and vertically accurate in relation to each other, and in relation to the door.

Do not install the lock where it will involve cutting into a joint between the door stile and a mid-rail.



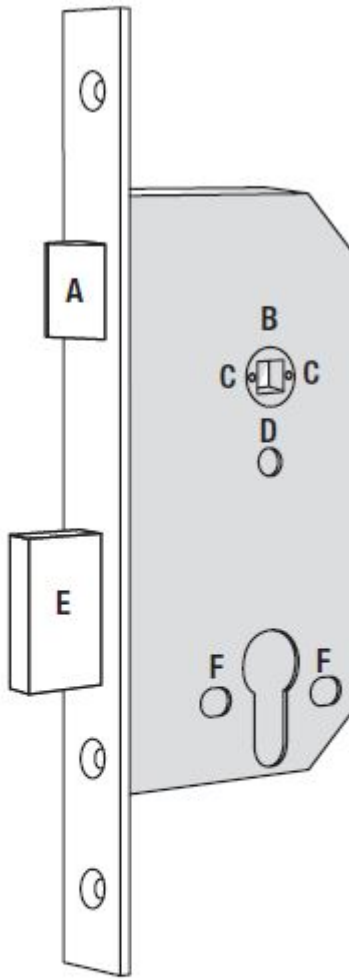

- A** Reversible latchbolt
- B** 2 part follower
- C** Set screws
- D** Hole for Code lock fixing bolt
- E** Double-throw 22mm ( $\frac{7}{8}$ " ) deadbolt
- F** Holes for keyhole-cover fixings

1. Lightly mark a height line on the edge and both faces of the door, and the door jamb, to indicate the top of the lock when fitted. Mark a line down the centre of the door edge, extending above the height line and 300mm ( $11 \frac{3}{4}$  ") below it.
2. Hold the mortice lock template against the edge of the door with the top in line with the height line, and with the arrows in line with the 'Centre of Door Edge' line. Mark the positions of the fixing screws, and the holes to be drilled for the mortice.
3. Drill the marked holes 90mm ( $3 \frac{1}{2}$ " ) deep and form the mortice for the lock.
4. Fold the template accurately along the dotted line and tape it to the door face with the top in line with the height line, and the fold on the door edge. Mark the centres of all the holes to be drilled. Remove the template and repeat on the other face of the door.
5. Drill the holes from both faces of the door to improve accuracy. Do not drill right through the door as this will damage the door when the drill breaks through.

6. Check that the two screws have been removed from the follower on the lock case on the outside of the door. DO NOT remove the screws from both sides of the follower.

7. Install the lock case in the door and fit the cylinder. Confirm that the key will double-throw the deadbolt, retract the deadbolt, and retract the latchbolt.

8. Fit the self-adhesive gaskets to the front and back plates. The gaskets provide friction against the door so that it is not necessary to over-tighten the bolts to provide stability.

9. Cut the fixing bolts to the correct length. Measured from beneath the bolt head the length should be 'door thickness' plus approximately 15mm ( $\frac{5}{8}$ " ) to the nearest cutting point of the bolt.

**N.B.** Always cut the bolts at one of the reduced sections so as not to damage a thread. Use the cutting edge of pliers to crimp strongly several times around the selected cutting point. The surplus end should break off quite easily.

10. According to the door thickness, insert one of the short spindles into the outside follower of the lock case with the spring in the back of the keypad. Use the 22mm ( $\frac{7}{8}$ " ) spindle for doors between 35-50mm ( $1\frac{3}{8}$ " -2"), and the 28mm ( $1\frac{3}{8}$ " ) spindle for doors between 45-60mm ( $1\frac{3}{4}$ " - $2\frac{3}{8}$ " ). Insert the longest spindle into the inside follower with the spring.

11. Remove the battery cover from the back plate, and remove the battery pack. Apply the front plate over the spindle passing the cable through the door. Place the back plate over the spindle, pull the cable through and screw the fixing bolts through the front plate.

12. Pass the top bolt through the door into the front plate, and then the bottom bolt, to stabilise the assembly.

13. Connect the cables.

14. Fit the batteries and the battery cover. Fit the cylinder cover and the handles. The inside handle should retract the latchbolt, and the latchbolt should automatically project again when the handle is released. With the key turned 90° clockwise the outside handle should retract the latchbolt.

15. Enter the factory Master Code #12345678. The keypad will flash blue, and the handle will retract the latch.

16. Mark a vertical line on the door jamb half the door thickness away from the door stop. This gives the centre line of the strike plate. Align the strike plate template with the height line, with the arrow heads aligned with the centre line. Mark the fixing holes, and draw around the apertures for the latchbolt and the deadbolt. Chisel out the latch aperture to 12mm ( $\frac{1}{2}$ " ) deep, and the deadbolt aperture to 22mm ( $\frac{7}{8}$ " ) deep. Fix the strike plate with the top screw only and gently close the door. Ensure that the latchbolt enters its aperture easily and holds the door without too much 'play'. When satisfied, draw around the final position of the strike plate, remove it, and cut a rebate to allow it to fit flush to the surface. Re-fix the strike with both screws.



**CL4510**  
Tubular Mortice Latch

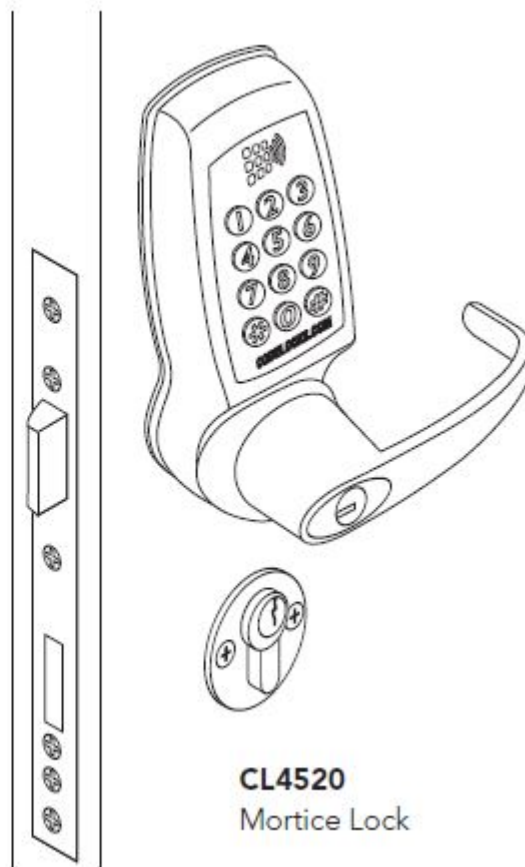

**CL4520**  
Mortice Lock

II-CL4500-v1:1016

© 2018 Codelocks Ltd. All rights reserved.

Keywords: Lock Locks Code CodeLock CodeLocks Program Programming Instruction Instruct Help Support Troubleshoot Troubleshooting Sequence Sequences NetCode Net NetCodes Install Installation K3 Connect Application App Android iOS Permissions Update Firmware Lock Parameters Settings Setting Parameter User Users Phone Card Client Setting Set up Register CL CL4500 4500 4510 CL4510